



Audio Engineering Society

Convention Paper 7448

Presented at the 124th Convention
2008 May 17–20 Amsterdam, The Netherlands

The papers at this Convention have been selected on the basis of a submitted abstract and extended precis that have been peer reviewed by at least two qualified anonymous reviewers. This convention paper has been reproduced from the author's advance manuscript, without editing, corrections, or consideration by the Review Board. The AES takes no responsibility for the contents. Additional papers may be obtained by sending request and remittance to Audio Engineering Society, 60 East 42nd Street, New York, New York 10165-2520, USA; also see www.aes.org. All rights reserved. Reproduction of this paper, or any portion thereof, is not permitted without direct permission from the Journal of the Audio Engineering Society.

How to widen the sweet spot in monitoring 5.1

Julien Bassères¹, and Patrick Thevenot²

¹ Taylor Made System, Nangis, 77 730, France
julien.basseres@free.fr

² Taylor Made System, Nangis, 77 730, France
patrick.thevenot@taylormadesystem.com

ABSTRACT

Generally speaking, sound reproduction tends to achieve the widest sweet spot.

But it's seldom realized and more than that, the restricted sweet spot has become rather usual and well accepted by the audio community.

This paper proposes to find a new approach in order to get a wider sweet spot, up to a certain extend, in multi channel.

By optimizing the directivity of each loudspeaker in order to compensate the position of the listener, this method aims at creating a coherent and homogeneous acoustic field.

Special care will be given to the directivity pattern (amplitude and phase) of the loudspeaker system.

1. THE PROBLEMATIC OF THE LISTENING POSITION IN MULTICHANNEL ITU 5.1

1.1. The lack of localization outward the center of the loudspeaker area

According to European Broadcasting Union (EBU) and Audio Engineering Society (AES) conditions (see [1], [4], [5]), the listening area (sweet spot) is limited, more or less, to a circle (radius of 0,8m) centered inside the ring drawn by the placement of each loudspeaker in 5.1.

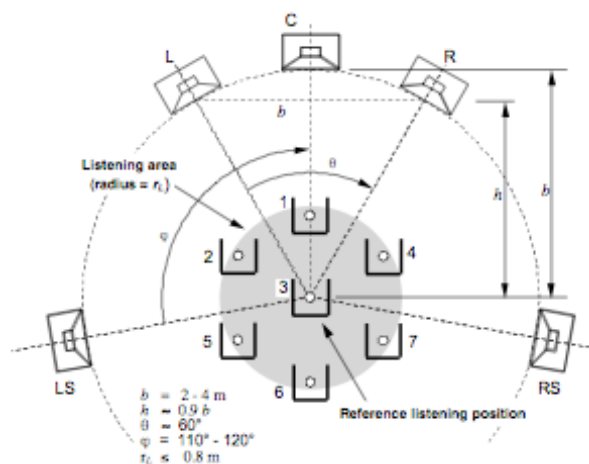

Figure 1 - EBU typical layout of five channel listening arrangement

But, in terms of localization, the sweet spot is strictly limited to the really center of this circle, which is called “the reference listening position”. When the listener deviates from this place, he approaches from the influence of one of the loudspeakers, which deforms the spatial localization.

The aim of the study is to propose a multichannel set-up that would widen the sweet spot.

One approach is to apply the stereophony principle used for microphones to loudspeaker. The listener deviation should be seen like a time’s difference (Δt) created between his new place and the reference listening position. Intensity’s difference (ΔI) will be occurred by using an adapted directivity for each loudspeaker in order to compensate the introduced time’s difference (Δt) (see Figure 2).

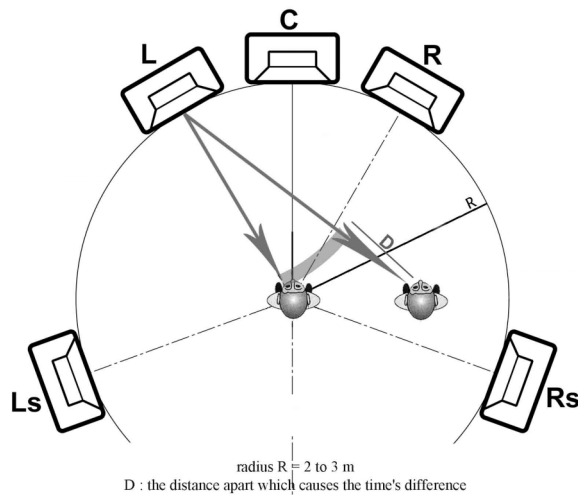

Figure 2 - $\Delta t/\Delta I$ compensation

First of all, let’s determinate the appropriate listening area.

1.2. The optimized listening area

By applying the stereophony principles, it’s impossible to cover perfectly the whole area circumscribed in the circle of the loudspeaker’s placement.

Actually, the optimized area is limited to a curve that is defined by the directivities of the loudspeakers (see some example in Figure 3).

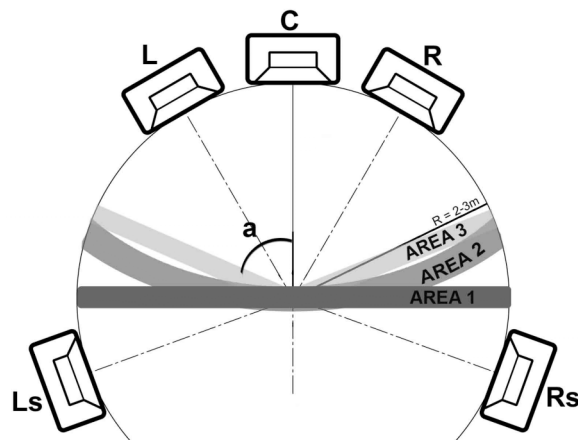

Figure 3 - Theoretical listening area in optimized 5.1

For practical reasons in this example, every area crosses the reference listening position.

And finally, the first area seems to perfectly fit to a lot of situations. We can imagine, at home, several people

in a sofa, or a sound engineer working behind an audio desk.

Notice that the third area would have been better for the lateral perception.

1.3. The loudspeaker compensation

By converging the loudspeakers in front of the sweet spot, the intensity's difference (ΔI) between each pair should compensates every listener's movement (see Figure 4).

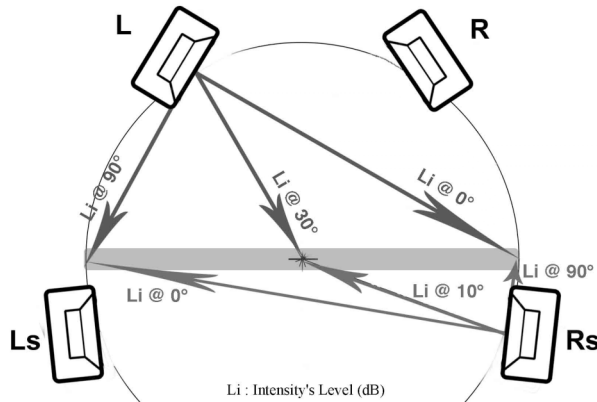

Figure 4 - $\Delta I/\Delta I$ compensation by converging the loudspeakers

For example, when the listener is at the right extremity of the listening area. In the front field, the Left loudspeaker is pointing him whereas the Right loudspeaker is facing at nearly 90°. If the loudspeakers are directive, it occurred intensity's difference (ΔI) between L and R loudspeakers.

If we want to keep the same coherence in localization than in the reference listening position, we have to find the adapted intensity's difference (ΔI) for each field in the whole optimized listening area.

From that, we have to define the adapted directivity for each channel.

1.4. Restrictions of this method

- In order to simplify the measures, the surrounds are placed at 110° during the whole study.
- It's impossible to optimize the listening condition in the entire area for each field. We can optimize the localization for only two fields. An initial experimentation, and former works about perception

(see [2], [3], [6]) revealed an important difference in perception's sensibility between the sides and the rear or the front. It drives us to take care more about the front and rear fields than the laterals.

- The Central loudspeaker won't make part of the study. First, the directivity, which should be done to always obtain the same level in the area, is quite impossible to create for the moment. Secondly, the typical use of the central speaker, according to several sound engineers, is to point out some sources, like for example a voice. Localization, in that case, is naturally done by the typical use of it.
- We won't speak about the Subwoofer channel. His placement depends on the acoustic of the room, and generally speaking, it's quite complicate to control the speaker's directivity under about 400Hz.

2. DETERMINATION OF THE INTENSITY'S CORRECTION BY EXPERIMENTATION

2.1. Procedure

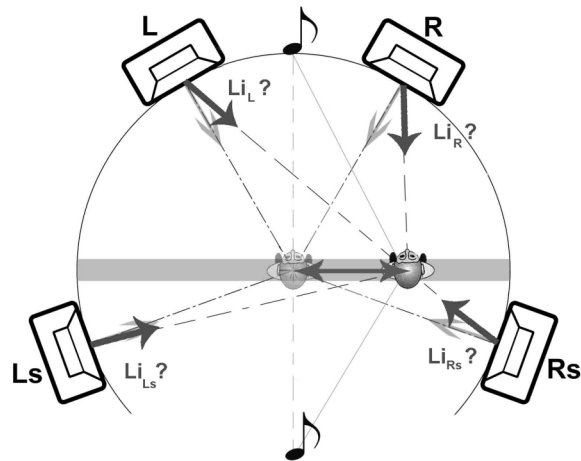

Figure 5 - test's procedure

The listener has been asked to deviate from the central reference position at several distances in the listening area. In each position, he had to perceptively replace a monophonic source on the virtual center (represented by a note) by using an intensity corrector for the rear and the front field. The sides were evicted from the test.

The monophonic signal was a female voice filtered, with a slope of 24 dB/octave, in several bandwidths (precisely “Tom’s dinner” by Suzanne Vega). The bandwidths were centered at 500 Hz, 2 kHz and 8kHz and wide about 2 octaves. A musical signal was chosen instead of pure frequency signal for the comfort of the auditor during this long test (about 45 minutes).

The measures were taken at 20 cm, 30 cm, 50 cm, 80 cm, 1m and 1m20 (nearly in front of one loudspeaker) of deviation.

20 persons did that test, and the public had mostly a sound’s experience.

2.2. Results

The loudspeakers were always facing the listener, in order not to take care about their directivities. The loudspeakers were placed at 2,5m of the reference listening position.

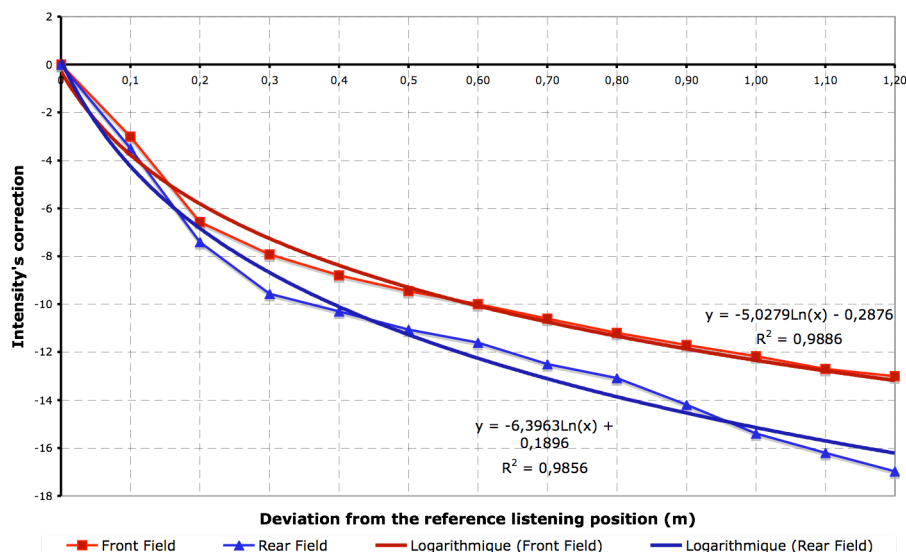

Figure 6 - Average representations of ΔI the causes by the deviation

Deviation	0	20cm	30 cm	50 cm	80 cm	1m	1,20m
Average FRONT @ 500hz (in dB)	0	-6	-7,6	-9	-11,7	-12,7	-13,6
Average FRONT @ 2khz (in dB)	0	-6,6	-7,5	-9,2	-10,6	-11,3	-12,2
Average FRONT @ 8khz (in dB)	0	-7,1	-8,7	-10,2	-11,4	-12,6	-13,3
Total average FRONT (in dB)	0	-6,6	-7,9	-9,5	-11,2	-12,2	-13
Average REAR @ 500hz (in dB)	0	-7,4	-8,9	-10,6	-12,8	-14,8	-16,6
Average REAR @ 2khz (in dB)	0	-7	-9,3	-10,9	-13,2	-15,8	-17,5
Average REAR @ 8khz (in dB)	0	-7,8	-10,2	-11,7	-13,3	-15,7	-16,8
Total average REAR (in dB)	0	-7,4	-9,4	-11,1	-13,1	-15,4	-17

The complete results of the experiment can be seen in the reference [2].

- The intensity's correction quickly becomes rather strong. At 20 centimeters deviation, we can find 6 or 7 decibels of correction. It points out how instable can be the multichannel's image just by moving the head from the exact center!
- The intensity's correction doesn't depend on the frequency; the results were quite similar for the three bandwidths. This will determinate the type of loudspeaker.

3. LOUDSPEAKER CONDITIONS

3.1. Amplitude's directivity

For this case, the ideal loudspeaker should have a constantly controlled directivity for the whole frequencies.

There are 3 main families of directivities for loudspeaker:

- Omnidirectional sources.
- Constant controlled directivity.
- Increasing controlled directivity.

Those families are represented in Figure 7. Unfortunately, it's quite complicated to create real directive bass, and generally, the directivity is controlled and maintained over about 400hz (see Figure 8).

In order to fit to the required conditions, the perfect loudspeaker should correspond to a constant directivity even though an increasing directivity should be tolerated up to a certain extend.

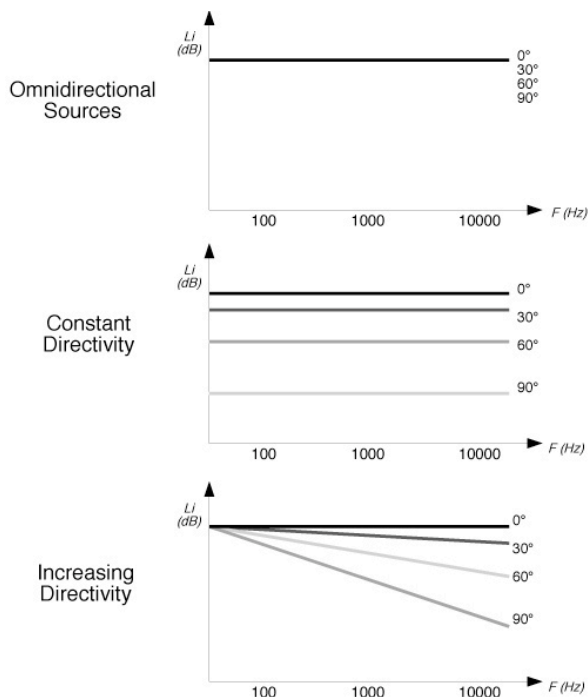

Figure 7 - Kinds of directivities

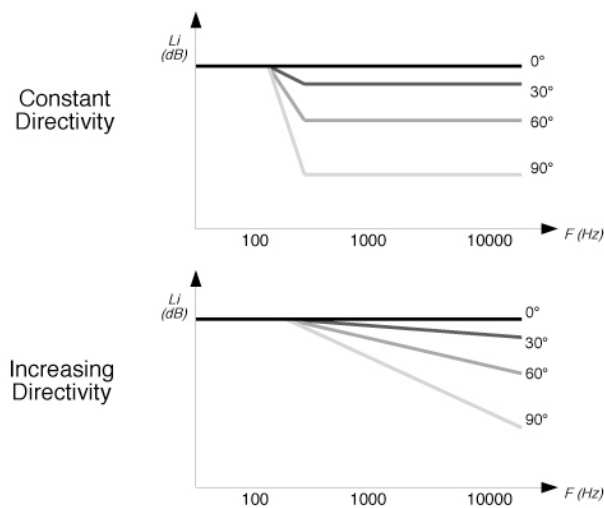

Figure 8 - Real loudspeakers responses

3.2. Phase's coherence

The temporal acoustical signature should be the same all around the loudspeaker, in order not to add some time's difference (Δt) and create a coherent acoustic field (see Figure 9).

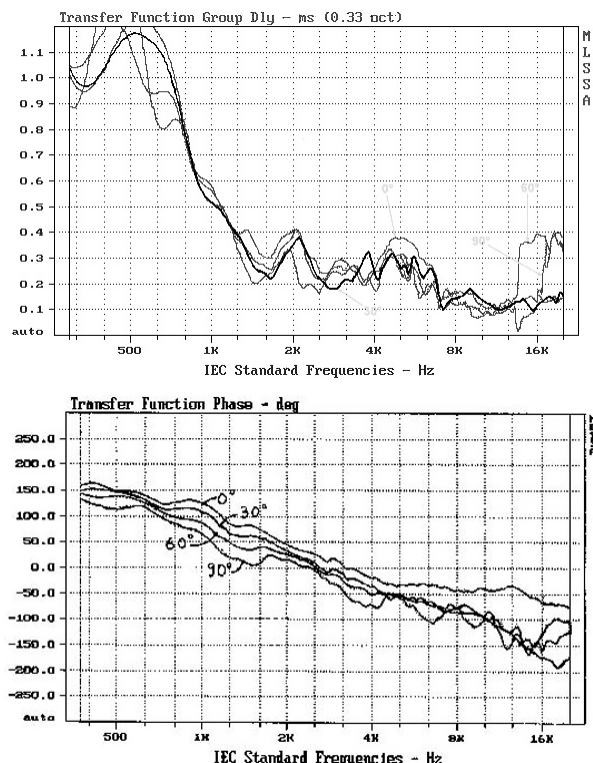

Figure 9 - Examples of coherent phase and group delay transfer functions all around the loudspeaker

4. DEVELOPMENT OF THE DIRECTIVITIES

4.1. Directivity function of the listening distance

The directivity requirements depend on the radius of the loudspeakers placement and there pointing deviation. The following directivities define those specifications. For example on Figure 10, the first loudspeaker is at 1 meter and the pointing deviation is at 1 meter (@1m/1m). The second is at 4 meter and pointing at 1 meter (@4m/1m). The last one will certainly need to be a more directive, because the deviation between 1 meter on the right to 50 centimeters on the left causes an angle

of less than 20 degrees. Whereas in the first example, the same deviation causes an angle of about 60°.

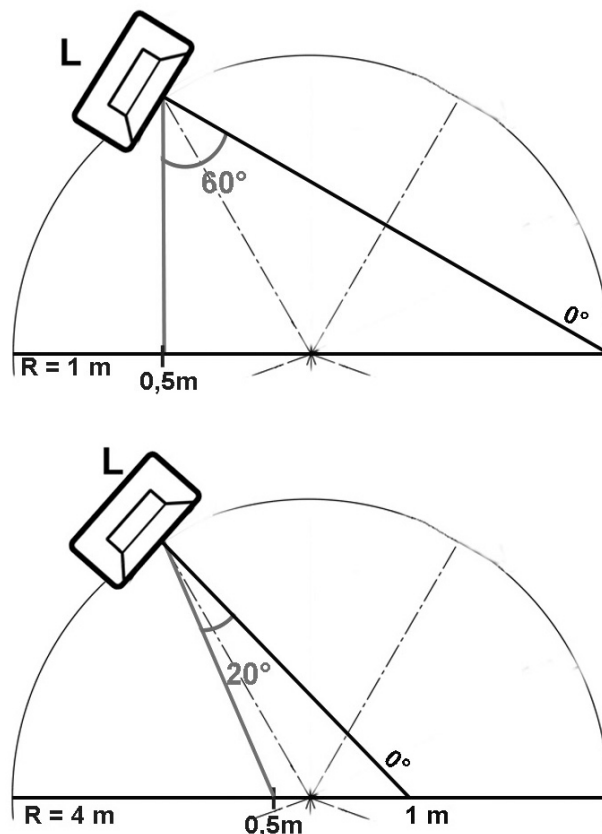

Figure 10 - Influence of the distance and the pointing deviation

4.2. Example of loudspeaker directivities

According to the results found in point 2.2, it's quite easy to determine the front and rear directivities. For larger distances than 2,5 meters, the results are interpolated by the logarithmic tangents (the functions and the curves are shown in Figure 6). The loudspeaker in each field should have a symmetrical response. The intensity's difference (ΔI) should be equally shared between the two speakers of the field.

Figure 11 to Figure 18 represent possible rear and front polar patterns for loudspeakers placed at 1 m (pointing at 1 meter), 2,50 meters (pointing at 1,20 and 2,50 meters), and 4 meters (pointing at 1,20 meters).

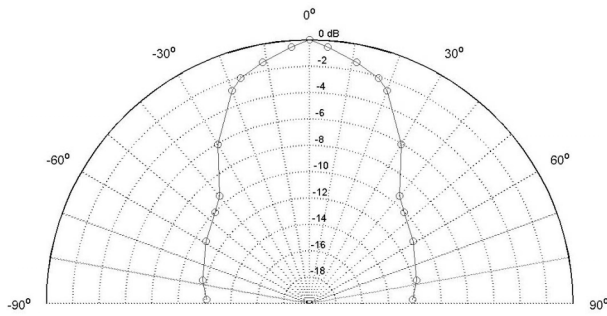

Figure 11 - Front directivity @1m/1m

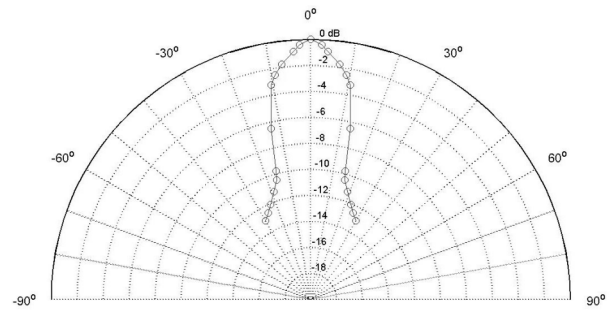

Figure 15 - Front directivity @ 4m/1,20m

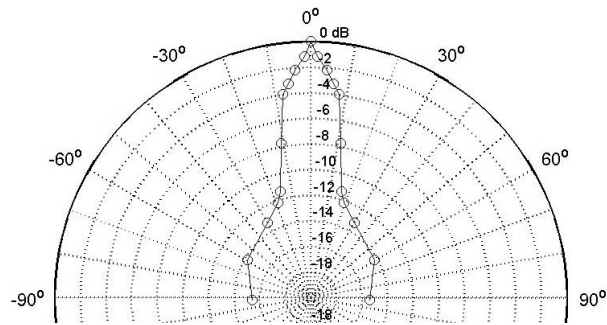

Figure 12 - Rear directivity @1m/1m

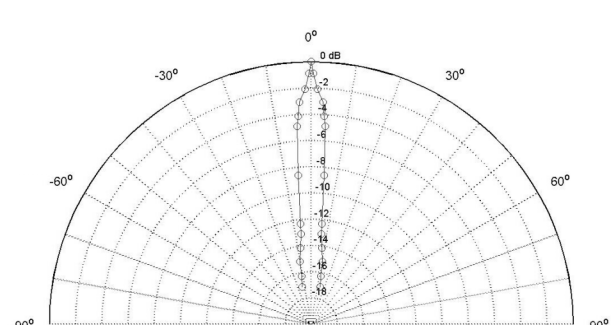

Figure 16 - Rear directivity @ 4m/1,20m

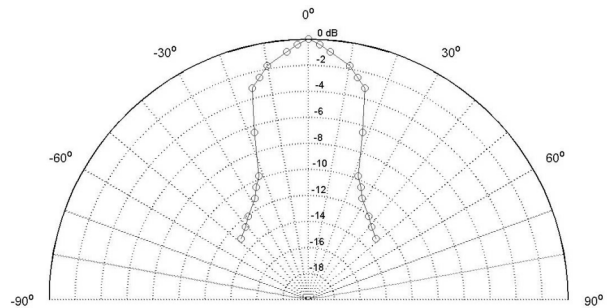

Figure 13 - Front directivity @ 2,50m/1,20m

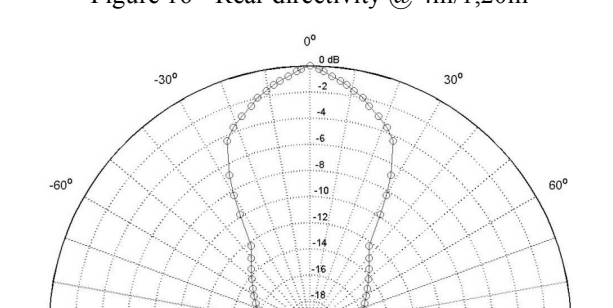

Figure 17 - Front directivity @ 2,50m/2,50m

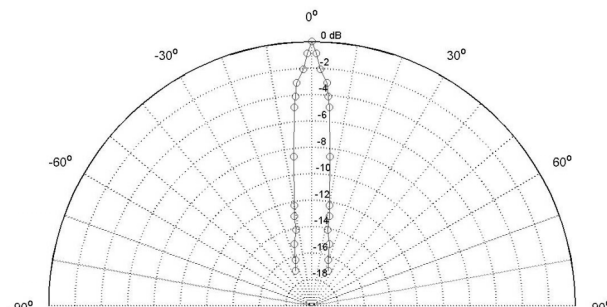

Figure 14 - Rear directivity @ 2,50m/1,20m

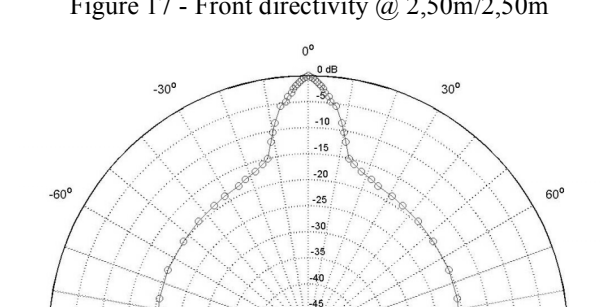

Figure 18 - Rear directivity @ 2,50m/2,50m
(the special representation is due to a problem of scale not resolved in Matlab. But the results are similar to the others)

By the way, the loudspeakers should be really directives, especially for the rears. The coverage angle (-6 dB point) should be:

- At 1 m: 60° for the front and 20° for the rear. Those criterions are quite easy to fulfill. This solution can be adapted for near field monitoring in studio's applications.
- At 2,5 m: pointing at 1,20m, we obtain a coverage angle of 40° for the front and almost 10° for the rear. But, when we point the loudspeaker at 2,5 meters, it grows up to 60° and 20°, nearly the same angles than at 1 meter. This proposition can be adapted to home's application and classical monitoring in studios.
- At 4 m: we obtain 30° for the front and almost 5° for the rear. Those directivities are too tight (especially the rear one), and quite impossible to realize for the moment.

5. CONCLUSIONS AND ISSUES

The appropriate solution to widen the listening area in multichannel is to use loudspeakers with a constant controlled directivity and a coherent omnidirectionnal phase. Their directivities depend on the listening distance. The loudspeakers are pointing the sides of the reference listening position, in order to compensate the auditor's deviation by intensity's difference and recreate the multichannel's image in the whole wider sweet spot. The new listening area is a line passing by the reference listening position, and which is parallel to L, R and Ls and Rs couples.

To conclude, this method presents some difficulties:

- **The using point of view.** It is not a "plug and play" system. It should be adapted to the distance and the loudspeaker's angulations. It requires some adjustments and optimizations. In domestical applications, this system is intended much more for upper audiophiles. In professional applications, this system will run up against the practices. Sound engineers are accustomed to see loudspeakers oriented into the ideal center. Even though, this system presents a lot of improvement in term of space, stability. And, up to a certain extend, we can imagine that the use of such a material can standardize some listening conditions in multichannel.

- **The conception's point of view.** For the moment, classical monitoring owns omnidirectionnal or increasing controlled directivity. Constant controlled directivity is seen in sound reinforcement. And it seems to be really difficult to make a compact loudspeaker with such a tight and maintained directivity. The solution must be adapted to distance and pointing, why not imagine loudspeakers with adaptive directivity? Finally, in order to let the visual loudspeaker orientation, why not using dissymmetric directivities?

6. ACKNOWLEDGEMENTS

This work is an evolution of a memoire done by Julien Bassères, during his studies in l'Ecole Nationale Supérieure Louis Lumière (France)

Laurent Givernaud, David Abia, Anne-Camille Le Heuzey Bensat, Jacques Fuchs, Yann Magnin, and all the auditors of the tests supported this work. L'Ecole Nationale Supérieure Louis Lumière, Taylor Made System and APG supported technically this study.

7. REFERENCES

- [1] AESTD1001.1.01-10 (2001) Multichannel surround sound systems and operation. *AES technical council*
- [2] BASSERES Julien (2006) Etude sur la directivité optimale des enceintes placées en configuration 5.1 dans le but d'un élargissement de la zone d'écoute. (Study on the optimal loudspeaker's directivity in 5.1 configuration in order to widen the listening area). *Mémoire of l'Ecole Nationale Supérieure Louis Lumière*
- [3] BLAUERT Jens (1997) Spatial hearing: The psychophysics of human sound localization. *MIT Press*
- [4] EBU-UER TECH 3276-E SUPPLEMENT 1 (2004) Listening condition for the assessment of sound program material: multichannel sound. *EBU-UER technical specification*
- [5] ITU-R BS.775-1 (1994) Multichannel stereophonic sound system with and without picture. *ITU technical council*

- [6] THEILE G. & PLENGE G (1976) Localization of lateral phantom sources. *Journal of the Audio Engineering Society*, vol 25, N°4, 1976 March
- [7] THEVENOT Patrick (1999) Influence du local sur l'écoute monitoring (Room's influence on the monitoring). *Document of the Institut National de l'Audiovisuel*